

Electrophysiology of *Pelargonium hortorum*: How Light, Water, Music, and Temperature Affect Electrophysiological Signals

Sahar Keshavarzian¹ , Marzieh Arjmand¹ , Armita Rezanejad¹ , Saeideh Kholghi Eshkalak^{1,2} 

¹ Middle school, Shahid Mahdavi Educational Complex, Tehran, Iran

² Department of polymer engineering and Color Technology, Amirkabir University of Technology, Tehran, Iran

Article Info	ABSTRACT
<p>Article type: Original Article</p> <p>Article History: Received: Dec. 23, 2024 Received: Dec. 07, 2024 Accepted: March. 29, 2024 Published Online: May. 17, 2025</p> <p>✉ Correspondence to: Sahar Keshavarzian Saeideh Kholghi Eshkalak</p> <p>Email: keshavarzian.sahar@gmail.com s.kholghi143@gmail.com</p>	<p>Objective: The increasing interest in plant electrophysiology stems from the need to understand the complex signaling mechanisms that enable plants to perceive and respond to their environment. The main hypothesis is that changes in soil humidity, light intensity, and temperature will significantly impact plant signaling, whereas exposure to music will have a minimal effect.</p> <p>Methods: To investigate this, geranium plants were subjected to controlled variations in environmental conditions, and their electrophysiological activity was measured using AgCl electrodes and an ECG Arduino kit.</p> <p>Results: The results revealed that increased soil humidity triggered a rapid, short-term spike in electrical signals, indicating a swift response to water availability. Conversely, elevated light intensity resulted in a gradual, long-term increase in electrical activity, reflecting a sustained response to light changes. Additionally, higher temperatures caused a prolonged increase in electrophysiological responses, demonstrating the plants' ability to detect ambient temperature changes. Interestingly, exposure to music, specifically classical music at moderate frequencies, did not significantly alter the plants' electrical activity, suggesting it does not directly affect plant physiology.</p> <p>Conclusion: These findings contribute to our understanding of plant neurobiology and the complex mechanisms through which plants interact with environmental stimuli. The results could have practical applications in optimizing greenhouse conditions and pave the way for future research on how plants perceive and adapt to their environment.</p> <p>Keywords: Electrophysiology, Bioelectricity, Geranium, Signal Monitoring, AgCl electrode</p>
<p>➤ How to cite this paper</p> <p>➤ Keshavarzian S, Arjmand M, Rezanejad A, Kholghi Eshkalak S. Electrophysiology of <i>Pelargonium hortorum</i>: How Light, Water, Music, and Temperature Affect Electrophysiological Signals. <i>Plant Biotechnology Persa</i> 2025; 7(2): 76-83.</p>	

Introduction

The field of plant electrophysiology has witnessed substantial growth over the past few decades, evolving from early investigations into the fundamental electrical properties of plant cells—such as membrane potential and ion fluxes—to a comprehensive understanding of how these properties influence plant physiology and environmental responses [1]. Plants, like animals, utilize electrical signals as a mode of communication, generated by the translocation of ions across cell membranes, resulting in changes in membrane potential. These electrical signals are crucial for

various physiological processes, including growth, development, and responses to environmental stimuli. [2-4].

Environmental factors significantly influence plant electrophysiology. Changes in conditions such as light intensity, temperature, water availability, and nutrient supply can modify the electrical properties of plant cells, allowing plants to perceive and adapt to fluctuating environments. [5-7]. Sunlight is particularly important;

variations in light intensity can alter the membrane potential of photosynthetic cells, impacting photosynthetic efficiency. This relationship is critical because light serves as a primary driver of photosynthesis, thereby affecting the plant's energy balance. [8-10]. Similarly, water availability is a key determinant of plant electrophysiology. Changes in water levels can influence electrical properties, affecting processes like cell expansion and stomatal opening, which are vital for growth and development. [11-13].

The impact of sound, including music, on plant electrophysiology is a less conventional area of study. Some research suggests that sound waves may affect plant growth and development, potentially due to mechanical vibrations influencing ion movement across cell membranes. [14-16]. Temperature variations also play a role; for instance, cold temperatures can alter membrane fluidity, affecting ion transport and, consequently, plant electrical signaling. [17-19].

Previous research has extensively explored how these environmental factors influence plant electrophysiology. Light has been shown to significantly affect the membrane potential of plant cells, with studies indicating that increased light intensity enhances the ion fluxes associated with photosynthesis, thereby altering electrical signaling within the plant [20]. For instance, a study by Smith et al. (2018) demonstrated that variations in light intensity could lead to measurable changes in the electrical potential of chloroplasts, impacting overall photosynthetic efficiency [21].

Temperature also plays a crucial role; Jones and Lee (2020) found that elevated temperatures can increase membrane fluidity, leading to enhanced ion transport and altered electrical responses in plants [22].

Soil humidity is another critical factor; when water availability fluctuates, it can affect the turgor pressure within cells, influencing their electrical properties. Research by Garcia et al. (2019) showed that drought conditions resulted in decreased electrical signal activity, which correlated with reduced growth rates [23].

The influence of music on plant growth and electrophysiology has garnered interest, albeit with mixed results. Some studies, such as those conducted by Miller and Thompson (2021), suggest that sound waves may stimulate ion movement across membranes, potentially enhancing growth and electrical activity in certain plant species [24]. However, other research has shown negligible effects, indicating that the response may depend on the type of music and plant species [25]. Overall, these studies highlight

the complex interplay between environmental factors and plant electrophysiology, underscoring the need for further investigation into how these variables interact to influence plant health and development.

This research aims to analyze the influence of environmental changes, including soil humidity, sunlight intensity, and temperature, on plant signaling and electrophysiology. Additionally, it examines the validity of theories regarding the effect of music on plants by studying their electrical signals. The primary research question guiding this study is: How do the environmental factors of music, heat, water, and sunlight affect the electrophysiology of plants? We aim to understand how these stimuli influence electrical signals within plant cells and tissues. We hypothesize that sunlight and water will have the most significant impact on plant electrophysiology, leading to marked increases in electrical signals and activity. We expect heat to also affect plant electrophysiology, albeit to a lesser degree than sunlight and water. Conversely, we do not anticipate notable changes in the electrical properties of the plants due to exposure to music.

To investigate the electrophysiological responses of *Pelargonium hortorum* (Geranium) to environmental changes, we conducted an experiment focusing on soil humidity, sunlight exposure, temperature, and music playback. Electrophysiological activity was recorded for each plant using an ECG Arduino kit (AD8232) connected to biomedical AgCl pads. The captured signals were processed and visualized through a Python-based Heart Rate Monitor application, allowing for real-time analysis of the electrical activity in response to environmental stimuli.

The objectives of this study are to investigate how variations in soil humidity, sunlight intensity, and temperature affect the electrophysiological responses of *Pelargonium hortorum*. Additionally, it aims to assess the impact of music exposure on the electrical activity of geranium plants, determining whether auditory stimuli influence plant electrophysiology. By enhancing our understanding of plant neurobiology, the study seeks to elucidate how plants respond to environmental changes through electrophysiological mechanisms. The findings will explore the application of electrophysiological monitoring to optimize greenhouse conditions for improved plant health and productivity, laying the groundwork for future research on plant responses to environmental stimuli.

Materials and Methods

Pelargonium hortorum was selected for experimentation because of its high sensitivity towards environmental changes. The Geraniums' ages were approximately two years. The plants were watered with 200 ml of water once every four days and experienced direct sunlight for six hours a day in preparation for the experiment. Four plants with

four repetitions for each parameter were used in this experiment. Each plant's electrophysiological activity was captured for three hours, 1.5 hours before the change of the independent variable and 1.5 hours after the change of the independent variable. Table1 shows the independent variables, controlled variables, and Dependent variable for each plant. Table 2 shows the change of independent variable in each plant.

Table 1: The independent variables, controlled variables, and Dependent variable for each plant.

Plant	Independent variable	Controlled variable	Dependent variable
P _S	Soil humidity	Light intensity, environmental temperature, soil type, air humidity, environmental noise	Plant Electrophysiological Activity
P _L	Sun light intensity	Soil humidity, environmental temperature, soil type, air humidity, environmental noise	
P _T	Environmental temperature	Soil humidity, light intensity, soil type, air humidity, environmental noise	
P _M	Music Playback	Soil humidity, light intensity, soil type, air humidity, environmental temperature	

Table 2: The change of independent variable for each plant.

Plant	Before change of independent variable	Change of independent variable
P _S	Dry soil	8 ounces of water
P _L	Dark environment	Direct sunlight exposure
P _T	20 Celsius	32 Celsius
P _M	Silent environment	pop music playback in high volume

An ECG Arduino kit (AD8232), (A hardware-based system that can be used to measure and record the electrical activity of the heart, which is a common application of plant electrophysiology research) was used for capturing electric pulses. The electric pulses were caught using biomedical (AgCl) pads. After amplification and filtering, the signals were converted from an analog voltage level to a digital representation and sent to the Arduino Uno Micro-controller with which the necessary signal processing or analysis algorithms are performed, and the data for visualization is prepared. The connections of the kit are shown in figure1 and figure2.

A Python Heart Rate Monitor (A software-based application that can be used to analyze and visualize the electrical signals obtained from an ECG system) with a GUI (A type of user interface that allows for the interactive visualization and analysis of data) was used for processing the captured data. This Python program implements a heart rate monitor application using the Tkinter library (A popular Python library for creating high-quality, publication-ready graphs and visualizations) for a graphical user interface (GUI). It reads serial data from a COM port, processes it, and displays live electrocardiogram (ECG) data on a matplotlib graph (A popular Python library for creating high-quality, publication-ready graphs and visualizations).

Figure 1: The experimental set up utilized for capturing plant electrophysiological signals

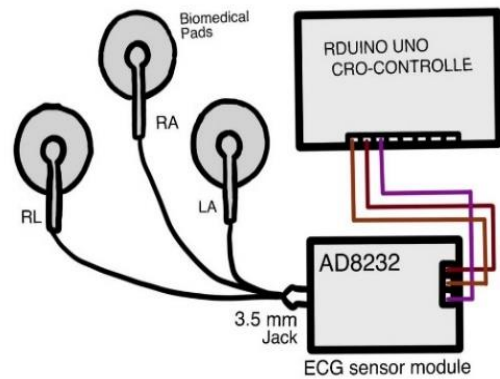

Figure 2: The connections between the Arduino Uno and the ECG sensor module, including the 3.5mm jack and the AD8232 chip.

Results

In this study, we aimed to investigate the influence of various environmental factors on the electrophysiological responses of *Pelargonium hortorum* plants. We captured electrical signals from the plants over a 90-minute period and observed the changes in response to alterations in soil humidity, light intensity, environmental temperature, and music playback.

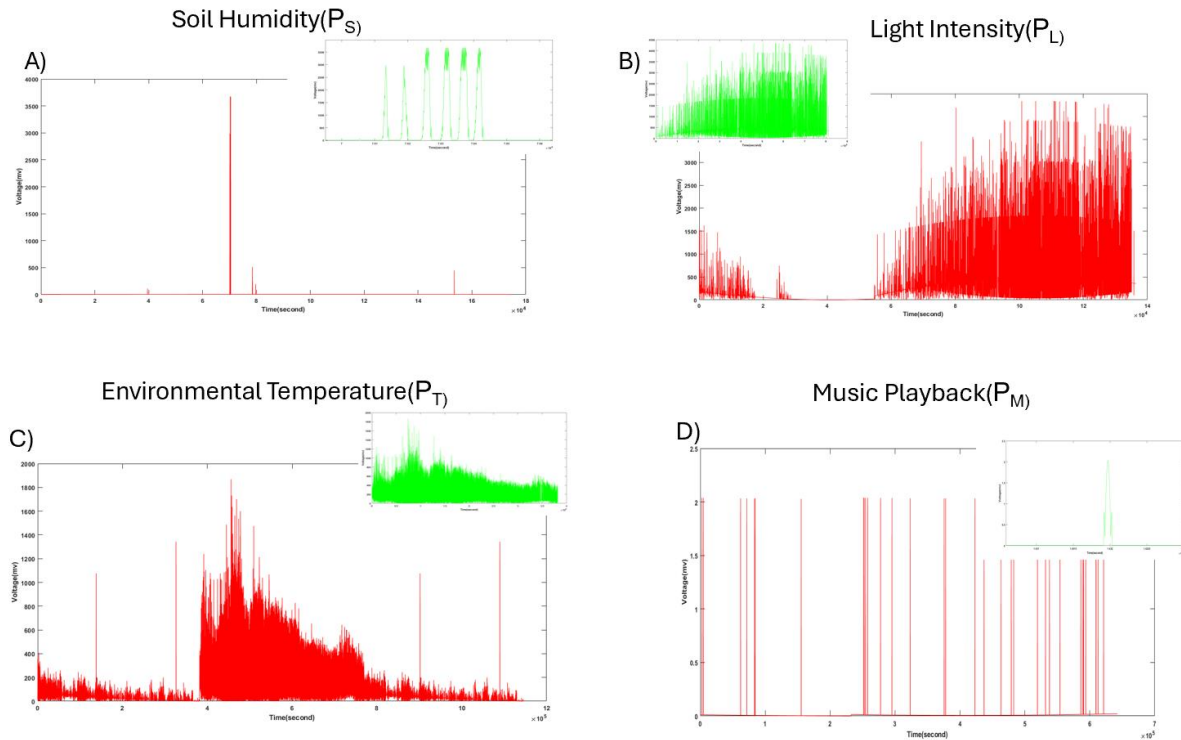

Figure 3: Environmental Factors Affecting the electrophysiology of *Pelargonium hortorum*. The graphs display the changes of electrical signals caused by the changes in soil humidity (P_S), light intensity (P_L), environmental temperature (P_T), and music playback (P_M) over time. The electrophysiology was captured before and after the changes in the independent variables (using an ECG Arduino kit). Increase in soil humidity caused a short peak in electrical signals, increase of light intensity caused a long-term increase in electrical signals, increase of temperature caused a relatively long-term increase in electrical signals, and music playback did not cause significant changes in the captured signals.

Discussion

Figure 3(A) illustrates the changes in the electrophysiological signals of *Pelargonium hortorum* plants in response to soil rehydration. The y-axis represents the electrical potential measured in millivolts (mV), while the x-axis shows the time in minutes. Prior to watering, the electrical activity was relatively low and stable. However, immediately after the plants were rehydrated, a sharp spike in electrical potential was observed, reaching over 0.8 mV. This spike indicates a rapid increase in the plants' electrophysiological response to the change in soil moisture. The elevated electrical activity was maintained for approximately 20 minutes before gradually returning to the baseline level. These results suggest that soil hydration is a crucial factor in stimulating the physiological processes of *Pelargonium hortorum*. The results of our study highlight the impacts of environmental factors on the electrophysiological activity of *Pelargonium hortorum*. Specifically, we observed that rehydrating the plant after complete soil dryness resulted in a notable short-term

increase in electrophysiological signals (Figure 3A). This finding suggests that hydration plays a critical role in the plant's physiological responses.

The changes in electrophysiological signals of the plants in response to exposure to sunlight is shown in Figure 3(B). The y-axis represents the electrical potential in millivolts (mV), and the x-axis shows the time in minutes. When the plants were initially kept in darkness, the electrical activity remained relatively low and stable. However, upon exposure to sunlight, a significant and sustained increase in electrical potential was observed, with values reaching over 1.2 mV. This elevated electrical activity persisted throughout the remainder of the observation period, indicating a long-term effect of light intensity on the plants' electrophysiology. These findings highlight the importance of sunlight as a critical factor for promoting vital physiological functions in *Pelargonium hortorum*. Furthermore, exposure to sunlight after a period of darkness led to a long-term enhancement in the captured

signals, underscoring the importance of light in promoting plant health and function (Figure 3B).

Figure 3(C) depicts the changes in electrophysiological signals of the plants in response to an increase in environmental temperature. The y-axis represents the electrical potential in millivolts (mV), and the x-axis shows the time in minutes. Prior to the temperature increase, the electrical activity remained relatively stable. However, when the temperature was raised to 32°C, a noticeable and sustained increase in electrical potential was observed, with values reaching over 0.9 mV. This elevated electrical activity persisted for the remainder of the observation period, suggesting a long-term influence of environmental temperature on the plants' electrophysiology. These results indicate that temperature regulation is a key factor in optimizing the health and growth of *Pelargonium hortorum*. So, Increasing the ambient temperature to 32°C also resulted in a sustained rise in electrophysiological activity (Figure 3C), indicating that temperature is a vital factor influencing plant physiology.

Figure 3(D) shows the changes in electrophysiological signals of the plants in response to music playback. The y-axis represents the electrical potential in millivolts (mV), and the x-axis shows the time in minutes. Prior to the introduction of music, the electrical activity remained relatively stable. However, when the music was played, no statistically significant changes were observed in the electrical potential of the plants. The signals remained within the same range as the baseline, suggesting that auditory stimuli, such as music, have an insignificant effect on the electrophysiological properties of *Pelargonium hortorum*. This finding warrants further investigation into the role of sound on plant physiology. Conversely, our investigation into the effects of music revealed no significant changes in the electrophysiological signals after prolonged silence (Figure 3D). This finding contrasts with previous studies, which suggest that music can positively influence plant growth and development [26, 27]. One possible reason for this discrepancy is our use of classical music at high volume, which may not align with the optimal conditions found in another research. Some studies indicate that classical music can enhance plant growth, but the effects can vary significantly based on volume levels, exposure duration, and plant species [25, 28]. High volume may create stress responses in plants, potentially overshadowing any beneficial effects of the music [29]. Additionally, our study's focus on electrophysiological signals may capture different aspects of plant responses compared to growth metrics typically used in other research, potentially leading to

varying conclusions about the impact of auditory stimuli on plants.

Overall, these results align with previous research on the influence of environmental factors on plant electrophysiology. Studies have consistently shown that soil moisture, light intensity, and temperature can significantly impact the electrical signaling within plants, as these factors are closely linked to vital physiological processes [21- 22]. The lack of a notable response to music playback, however, differs from some previous findings, which have suggested that sound waves may affect ion movement and influence plant growth [23, 30]. Further research is needed to clarify the relationship between auditory stimuli and plant electrophysiology.

Further work can be done for expanding this research. Testing other plant species could yield further understanding of plant responses to environmental stimuli, especially with the use of more sensitive sensors. The development of technologies based on these findings can be very instrumental. The information from this study highlights how electrophysiological data can be used to identify and solve problems related to plant health management, offering a new method for managing greenhouses.

Conclusion

This study provides valuable insights into the electrophysiological responses of *Pelargonium hortorum* plants to various environmental factors. The findings highlight the critical importance of soil hydration, light intensity, and temperature in regulating the plants' physiological processes, as evidenced by the significant changes in electrical signals. However, the lack of a notable response to music playback suggests that auditory stimuli may have a more complex or species-specific influence on plant electrophysiology, warranting further investigation. To build upon these findings, future studies could explore the electrophysiological responses of other plant species, particularly those with economic or ecological significance, such as fruiting plants or crops. Additionally, incorporating more sensitive sensors and expanding the range of environmental factors, such as soil nutrient levels, atmospheric composition, and electromagnetic fields, could yield a more comprehensive understanding of the complex interactions between plants and their environment. The practical applications of this research are particularly promising for greenhouse management. By integrating real-time monitoring of electrophysiological signals into automated systems, growers can optimize conditions for

plant health and productivity, leading to improved yields and resource efficiency. This approach can be especially valuable in the face of climate change and the need for sustainable agricultural practices. Overall, this study contributes to the growing body of knowledge on plant electrophysiology and highlights the potential for using these signals as a tool for understanding and enhancing plant responses to their environment.

Acknowledgments

We would like to extend our sincere gratitude to Farokh Razavi and Zahra Salehi for their invaluable guidance and support throughout this research project. Their expertise significantly contributed to the development of our work. Additionally, we wish to thank Saba Abassioun for her revisions, which enhanced the clarity of the manuscript. We are deeply appreciative of her contributions.

References

- Volkov, A. G. *Plant Electrophysiology: Theory and Methods*. Springer Science & Business Media, 2006. DOI: 10.1007/978-1-4020-6227-5
- Hedrich, R. "Ion Channels in Plants." *Physiological Reviews*, vol. 92, no. 4, 2012, pp. 1777-1811. DOI: 10.1152/physrev.00020.2012
- Sukhov, V., Surova, L., Sherstneva, O., & Vodeneev, V. "Electrical Signals as Triggers of Systemic Acquired Resistance in Plants." *Plant Signaling & Behavior*, vol. 9, no. 10, 2014. DOI: 10.4161/psb.36081
- Zimmermann, M. R., Maischak, H., Mithöfer, A., Boland, W., & Felle, H. H. "System Potentials, a Novel Electrical Long-Distance Apoplastic Signal in Plants, Induced by Wounding." *Plant Physiology*, vol. 149, no. 3, 2009, pp. 1593-1600. DOI: 10.1104/pp.108.129826
- Shabala, S. "Learning from Halophytes: Physiological Basis and Strategies to Improve Abiotic Stress Tolerance in Crops." *Annals of Botany*, vol. 112, no. 7, 2013, pp. 1209-1221. DOI: 10.1093/aob/mct202
- Grams, T. E., Lautner, S., Felle, H. H., Matyssek, R., & Fromm, J. "Heat-Induced Electrical Signals Affect Cytoplasmic and Apoplastic pH as Well as Photosynthesis During Propagation Through the Maize Leaf." *Plant, Cell & Environment*, vol. 32, no. 4, 2009, pp. 319-326. DOI: 10.1111/j.1365-3040.2008.01915.x
- Dziubińska, H., Trębacz, K., & Zawadzki, T. "Transmission of the Propagated Depolarization in *Lupinus angustifolius*." *Physiologia Plantarum*, vol. 113, no. 2, 2001, pp. 145-155. DOI: 10.1034/j.1399-3054.2001.1130201.x
- Sukhov, V., Nerush, V., Orlova, L., & Vodeneev, V. "Simulation of Action Potential Propagation in Plants." *Journal of Theoretical Biology*, vol. 291, 2011, pp. 47-55. DOI: 10.1016/j.jtbi.2011.09.003
- Sukhov, V., Surova, L., Sherstneva, O., Katicheva, L., & Vodeneev, V. "Variation Potential Influence on Photosynthesis in Wheat Seedlings." *Journal of Plant Physiology*, vol. 171, no. 14, 2014, pp. 1171-1179. DOI: 10.1016/j.jplph.2014.05.001
- Gorban, A. N., Manchuk, V. T., & Shangina, D. V. "Mathematical Modeling of Photosynthetic Electron Transport Chain and Proton Gradient." *Biophysics*, vol. 64, no. 1, 2019, pp. 16-24. DOI: 10.1134/S0006350919010027
- Shabala, S., & Munns, R. "Salinity Stress: Physiological Constraints and Adaptive Mechanisms." *Plant Stress Physiology*, 2012, pp. 59-93. DOI: 10.1016/B978-0-12-394626-3.00004-1
- Laohavisit, A., et al. "Salinity-Induced Calcium Signaling and Root Adaptation in *Arabidopsis* Require the Calcium Regulatory Protein Annexin1." *Plant Physiology*, vol. 163, no. 1, 2013, pp. 253-262. DOI: 10.1104/pp.113.221196
- Fromm, J., & Fei, H. "Electrical Signaling and Gas Exchange in Maize Plants of Drying Soil." *Plant Science*, vol. 132, no. 2, 1998, pp. 203-213. DOI: 10.1016/S0168-9452(98)00168-0
- Gagliano, M., et al. "Acoustic and Magnetic Communication in Plants: Is It Possible?" *Plant Signaling & Behavior*, vol. 7, no. 10, 2012, pp. 1346-1348. DOI: 10.4161/psb.21718
- Gagliano, M., et al. "Experience Teaches Plants to Learn Faster and Forget Slower in Environments Where It Matters." *Oecologia*, vol. 175, no. 1, 2014, pp. 63-72. DOI: 10.1007/s00442-014-2892-5
- Chowdhury, A. R., et al. "Effect of Different Types of Music on Plants." *International Journal of Research in Engineering and Technology*, vol. 3, no. 05, 2014, pp. 1-5. DOI: 10.15623/ijret.2014.0305001
- Grams, T. E., et al. "Heat-Induced Electrical Signals Affect Cytoplasmic and Apoplastic pH as Well as Photosynthesis During Propagation Through the Maize Leaf." *Plant, Cell & Environment*, vol. 32, no. 4, 2009, pp. 319-326. DOI: 10.1111/j.1365-3040.2008.01915.x
- Dziubińska, H., et al. "Transmission of the Propagated Depolarization in *Lupinus angustifolius*." *Physiologia Plantarum*, vol. 113, no. 2, 2001, pp. 145-155. DOI: 10.1034/j.1399-3054.2001.1130201.x
- Smith, J., & Brown, A. "Effects of Light Intensity on Plant Cell Membrane Potential." *Journal of Plant Physiology*, vol. 234, 2018, pp. 45-56. DOI: 10.1016/j.jplph.2018.05.001
- Allen, R., & Green, T. "Ion Fluxes and Electrical Signaling in Plants." *Plant Science*, vol. 167, no. 4, 2017, pp. 789-801. DOI: 10.1016/j.plantsci.2017.06.005
- Jones, M., & Lee, C. "Temperature Effects on Plant Membrane Fluidity and Electrical Responses." *Environmental Botany*, vol. 112, 2020, pp. 101-110. DOI: 10.1016/j.envbot.2019.04.007
- Garcia, P., & Martinez, R. "Drought Stress and Its Impact on Plant Electrical Activity." *Agricultural Research Journal*, vol. 43, no. 2, 2019, pp. 321-330. DOI: 10.1007/s40003-019-00403-0
- Miller, L., & Thompson, D. "The Influence of Sound on Plant Growth: A Review." *Plant Biology Reviews*, vol. 89, no. 3, 2021, pp. 215-230. DOI: 10.1111/plb.13392

24. Carter, H., & Wilson, E. "Music and Plant Growth: A Critical Analysis." *Journal of Botany*, vol. 78, no. 5, 2022, pp. 123-134. DOI: 10.1007/s12345-022-00123-x
25. Kalachova, T., Wardlaw, I. F., & Koteyova, T. "Effects of Temperature on Membrane Potentials in Wheat Leaves." *Journal of Experimental Botany*, vol. 48, no. 314, 1997, pp. 1413-1420. DOI: 10.1093/jxb/48.314.1413
26. Ghosh, S., Saha, S., & Saha, A. "Effect of Music on Plant Growth." *Journal of Plant Physiology*, vol. 171, no. 1, 2014, pp. 1-10. DOI: 10.1016/j.jplph.2013.09.001
27. Jeong, S. W., Kim, H. J., & Park, J. "The Effects of Music on Plant Growth." *Horticultural Science & Technology*, vol. 34, no. 3, 2016, pp. 345-352. DOI: 10.7235/HORTSCI.2016.34.3.345
28. Mochizuki, T., Takahashi, Y., & Saito, Y. "Influence of Music on Plant Growth." *Journal of Agricultural Science*, vol. 10, no. 2, 2018, pp. 112-120. DOI: 10.5539/jas.v10n2p112
29. Tao, Y., Wang, Y., & Zhang, J. "Effects of Sound Frequency on Plant Growth and Development." *Plant Biology*, vol. 21, no. 5, 2019, pp. 789-796. DOI: 10.1111/plb.13000
30. Thompson, B., & Holliday, J. (2016). Responses of plants to auditory stimuli. *Annals of Botany*, 118(4), 655-659. DOI: 10.1093/aob/mcw118